

RAP17 Series
(Real Action Paintball Pistol)
Operation & Maintenance
Manual

Before Starting

Check the RAP17 Accessories attached:

1 x RAP17 marker;
1 x Magazine;
1 x Refill Adaptor;
1 x Holster Sling Extension;
1 x Cleaning set;

Spare Parts:

2 x L-Keys;
1 x Adjusting Tool;
1 x Valve (3108);
1 x O-ring (3110);

 Warning	
 Adult Only	This paintball marker is not a toy nor is it intended for unsupervised use by any persons under the age of 18 years. Always keep in mind that the sport of Paintball will be viewed and judged upon your safe and sportsmanlike conduct.
 Sport Only	This paintball marker takes Co2 as energy source, takes paintball as projectile. This paintball marker must be used in the Real Action Exercise or Paintball Sport.
 Mask On	Do always wear eye protection in the form of approved goggles or full face mask and never shoot at a person who is not similarly protected.
 Read	Read the warning notice and user manual before you operate this paintball marker to prevent any unnecessary property damage or personal injury.

Dear User,

Please read the following note and instructions before you operate the RAP17:

Warning:

This Paintball Marker IS NOT a toy and DO NOT let unsupervised used by person under the age of 18 years old. Always keep in mind that the sport of paintball will be viewed and judged upon your safe and sportsmanlike conduct.

User must relieve the marker's stored internal air pressure each time the air tank is removed or turned off.

Action:

Make certain there is no paintball inside the receiver, point the marker in a safe direction and depress the trigger until all the air pressure has been relieved. Failure to do so may cause accidental firing, internal damage and may void your warranty.

Please wipe lubricant oil to the "Launching Compartment (3102)" before putting back into storage for protection.

Thank you for using our products.

Please contact us for any inquiry regarding maintenance or service.

Enjoy your Real Action Paintball Marker and play safely.

Real Action Paintball LLC
www.rap4.com

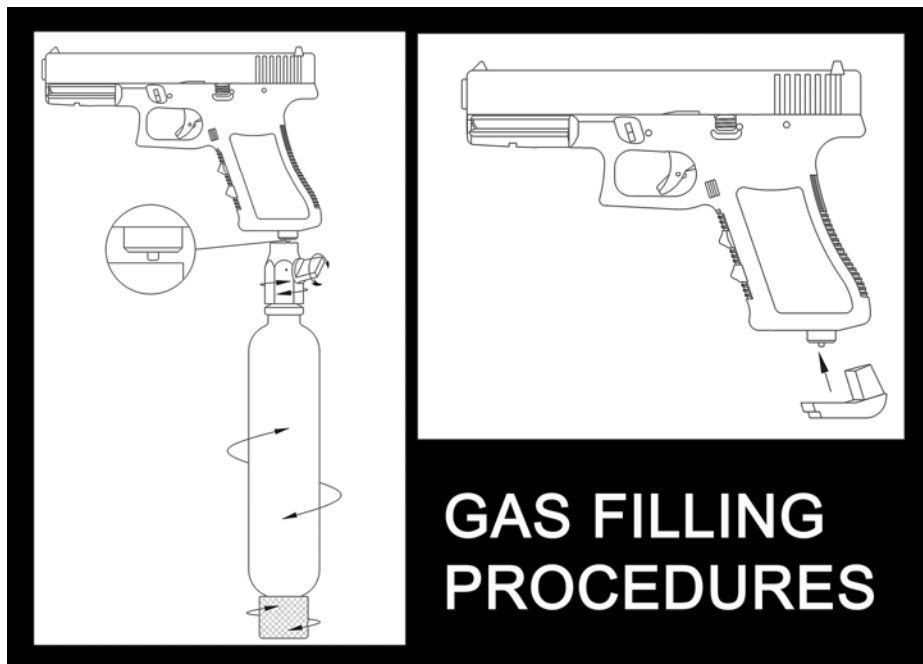

1. Push the “Cylinder Valve Pin (3719)” against table to empty the CO2 “cylinder (3715)”
 2. Check the refilling cylinder if it is filled with CO2
 3. Turn off (clockwise) the “Refill Adapter Switch (3804)”
 4. Connect the refilling cylinder with “Refill Adapter (3802)” and apply 2 drops of lubricate oil inside the “Refill Adapter (3802)”
 5. Connect the “Refill Adapter (3802)” with “Cylinder Valve (3716)”
 6. Turn on the cylinder switch and pull the “Trigger (3310)” five to seven times. Refilling takes about 20 seconds
 7. Turn off (clockwise) the cylinder switch
 8. Turn on (anti-clockwise) the “Refill Adapter Switch (3804)” and let the excess CO2 out
 9. Disconnect the “Refill Adapter (3802)”
 10. Put on the “Cylinder Cover (3518)” immediately to prevent damage to the “Cylinder Valve (3716)”
 11. The RAP17 takes about 10g of CO2 and can shot about 30 rounds for each refill.
- Notice: Temperature of refilling cylinder must lower than the pistol cylinder.**



1. Pull down the “Paintball Holding Nuts” on the magazine until it stays in the bottom and locked
2. Insert paintball into the “Magazine (3601)”
3. Cock back the “Slide (3402)” and halt the Slide with applying the “Slide Release Catch (3315)”
4. Insert the “Magazine (3601)” into the magazine housing
5. Press the “Slide Release Catch (3315)” down to let the Slide forward and load the paintball into the chamber

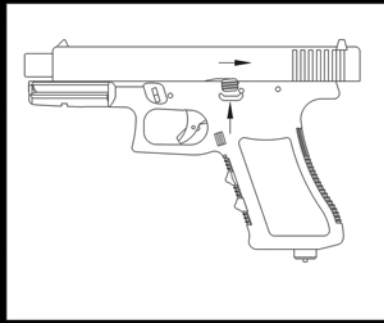

MAGAZINE UNLOADING PROCEDURES

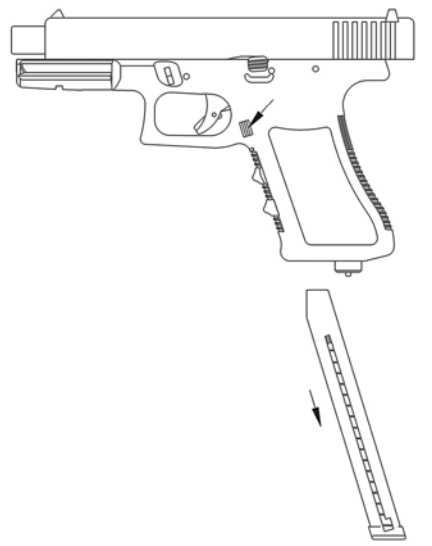

1. Ensure the Slide is cocked back or halt at backward
2. Press the “Magazine Release Catch (3514)” to release the magazine
3. Press down the “Slide Release Catch (3315)” to let Slide forward and point to the safe direction and pull the trigger once to ensure no paintball inside the chamber

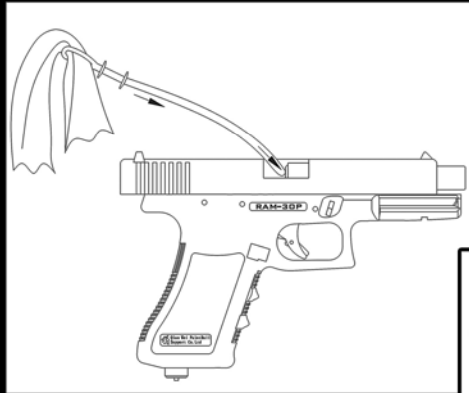

CLEANING BARREL PROCEDURES

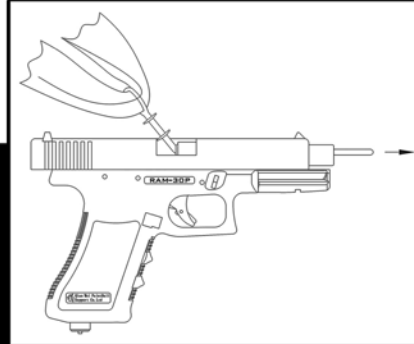

1. Pull back the "Slide (3402)" and halt with apply "Slide Release Catch (3315)" and ensure no magazine in the magazine housing
2. Pass one end of the "Cleaning Wire" through the barrel from the "Ejection Opening" and attach the "Cleaning Cloth" on the other end of the "Cleaning Wire"
3. Pull the "Cleaning Wire" from the barrel slowly
4. Repeat this procedure with a cleaned "Cleaning Cloth" if necessary

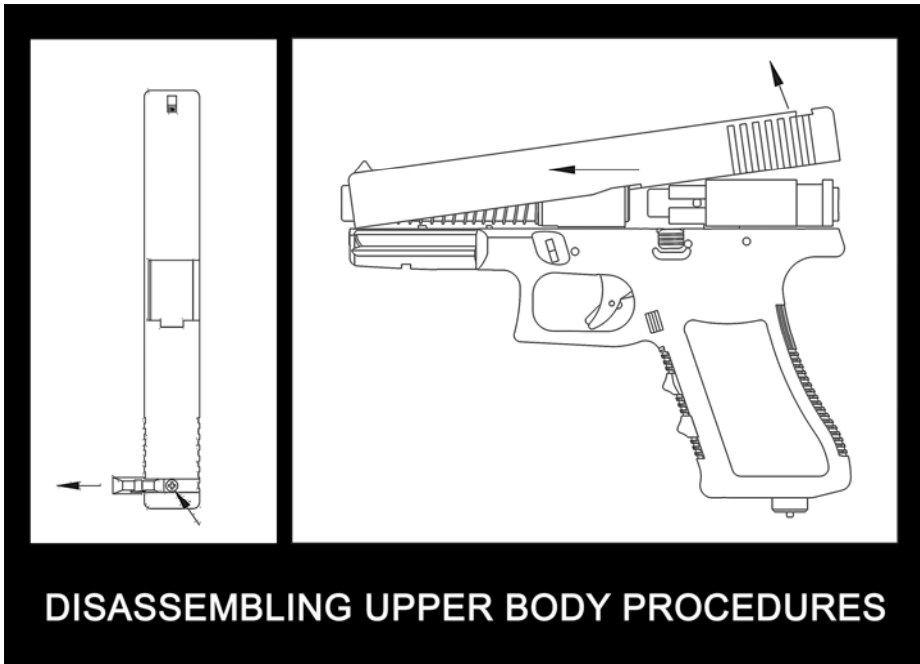

1. **EMPTY THE CYLINDER BEFORE ANY FURTHER ACTION TO BE TAKEN TO AVOID ANY UNNECESSARY INJURY**
2. Remove the "Rear Sight (3403)" either to left or right
3. Unscrew the "Slide Locking Screw (3404)"
4. Pull back the "Slide (3402)" and lift up the rear part of the "Slide (3402)" and forward the slide with under control and remove the slide out from the marker
5. Remove the "Slide Locking Screw (3407)"

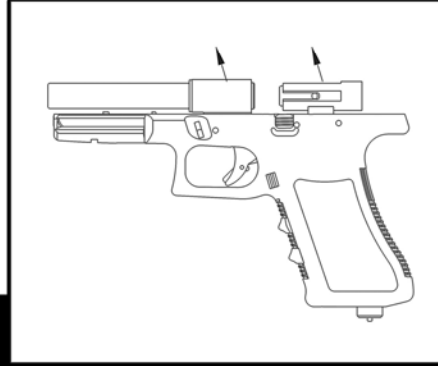
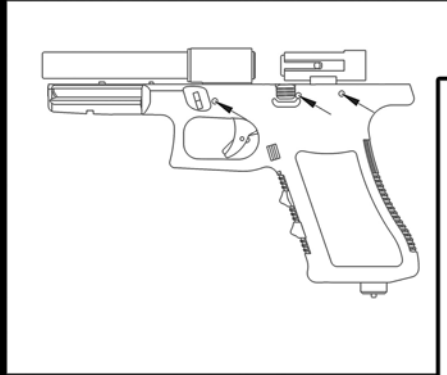

MARKER CORE DISASSEMBLING

1. Remove the upper body – the Slide (Refer to DISASSEMBLING UPPER BODY PROCEDURES)
NOTE: EMPTY THE CYLINDER BEFORE ANY FURTHER ACTION TO BE TAKEN TO AVOID ANY UNNECESSARY INJURY
2. Remove the “Trigger Stand Locking Pin (3510)”, “Launching Compartment Locking Pin (3511)”, and “Hammer Stand Locking Pin (3512)”
3. Pull out the core / inner part from the RAP17 pistol

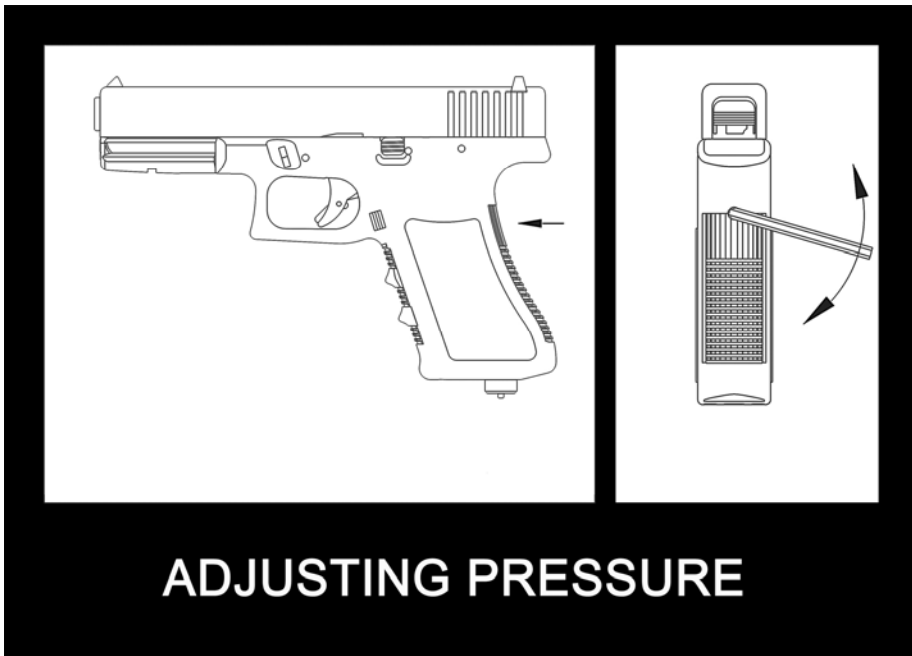

ADJUSTING PRESSURE

1. Remove “Pressure Adjust cover (3519)”
2. Use a provided L-Key to adjust the “Pressure Adjust Screw (3712)” through the hole in back of the pistol grip
3. Turn clockwise to increase the pressure and turn anti-clockwise to decrease the pressure

Note: Too much pressure will result in paintball breakage

RAP17 Series Trouble Shooting and Maintenance:

Situation	Reason	Solutions
Gas Leaking from the Slide	1. #3109 is not tight enough	Tight up #3109.
Re-cock function is not working after refill	1. Shoot too many blank shot while refilling (normally 4-5 times)	a. After disconnect the refill cylinder and shoot few blank shot with re-cock manually

- ◆ Procedure for Optimum Storage of RAP17 Projectiles
 - Keep the projectiles in a re-sealable bag.
 - Storage temperature should be 15 – 30 degree Celsius (60 – 85 degree Fahrenheit)
 - Storage humidity should be 65 – 80 percent
 - Do not allow the projectiles to freeze. They will lose their outer strength integrity
 - Remember the projectiles are sensitive to pressure, temperature and humidity
 - If you follow these few short procedures, the shelf life of the projectiles is approximately one (1) year

- ◆ Suggest that after each use, clean / dry up the barrel and put on some lubricant oil for protection.

- ◆ DO NOT store the RAP17 or accessories in a place over 45 degree Celsius

For enquiry, please contact your dealer or contact us.

Important Notices

- a. Read the User Manual carefully before using the Marker to avoid any unnecessary accidents or injuries.
 - b. Empty the CO2 cylinder before any maintenance to avoid unnecessary injury.
 - c. Only 18 years old or above to use the Marker.
 - d. Failure to follow the instructions may result in serious injury such as blindness and damage to the property.
 - e. Wear a protective mask or goggle at all time while using this marker to avoid paints and/or cartridge cases injury to the eyes.
 - f. DO NOT point or shoot with the Marker to any persons and yourself, it may cause blindness or other serious injury.
 - g. Keep the Gas Cylinder and the Marker away from fire or high temperature area (in excess of 113F or 45°C).
 - h. Only use Co2 to fill in the Gas Cylinder to operate the Marker.
 - i. DO NOT attempt to strip the Marker and gas cylinder when the gas cylinder is attached.
 - j. DO NOT load any pellets other than paintballs in the Marker.
 - k. Only suggested paintballs are used for the Marker.
 - l. DO NOT carry the Marker without case in the public area.
 - m. DO NOT ship the Marker or accessories except in the original package case.
 - n. DO NOT attempt to rebuild or modify the structure of the Marker. It may result in serious injury and damage to the Marker during use.
 - o. Remove the Gas Cylinder form the Marker after use, keep the Marker and the Gas Cylinder out of reach of the children at all time.
 - p. Ensure the adjustment of the muzzle energy (joule) of the Marker is within the limit of local laws.
 - q. Any injury during usage the Marker or any accessories should go to see Doctor immediately.
 - r. DO NOT ATTEMPT to repair the Marker or any accessories of this Marker by yourself, should refer to nearest Authorized Service Center.
- **DO NOT ATTEMPT to strip and assemble the Gas Cylinder or the main core**
 - **DO WEAR appropriate protective dress and mask when using the Marker**
 - **Suggest that after each use, clean / dry up the barrel and apply lubricant oil for protection.**
 - **DO NOT store the RAP17 or accessories in a place over 45°C.**