

RAP5
Real Action Paintball Marker
Operating & Maintenance
Manual

Before Starting

Check the marker and accessories attached;

1 X RAP5 marker;
1 X Co2 cylinder (45g rechargeable cylinder);
1 X Magazine;
1 pack (40rds) of 0.43 cal paintball; or
100 pcs of 0.40 cal empty cases

Spare Parts:

1 X O-Ring (5140)
1 X Cleaning Wire
1 X Screw Driver (wrench)

Accessories:

1 X VCD
1 X Marker Manual
1 X Marker Diagram
1 X Warranty Notice

S-Series Trouble Shooting and Maintenance:

Situation	Reason	Solutions
Not shooting during press the trigger.	1. Cylinder is empty 2. Forgot to turn on the cylinder 3. Jammed Paintball case in the barrel	Change cylinder; Turn on the cylinder; Take off the Magazine and take out the paintball case;
Shooting distance is not in the normal range	1. Marker core is leaking gas	a. Use the Pressure Meter to check the pressure if it is right (usually within 20-22 lb) b. Change #5140 O-ring
	2. #5146 is worn out.	Change the #5146
	3. Barrel is loosen	
Cartridge can't eject out	#5152 & #5153 is broken	Change the #5152 & #5153

** Suggest that after each use, clean / dry up the barrel and apply lubricant oil for protection.

** DO NOT store the RAP5 or accessories in a place over 45°C

** For more FAQ, please visit our website.

For Enquiry please contact:

Tel: (408) 727-3144

Fax: (408) 727-3135

Web Site: www.rap4.com

Email: info@rap4.com

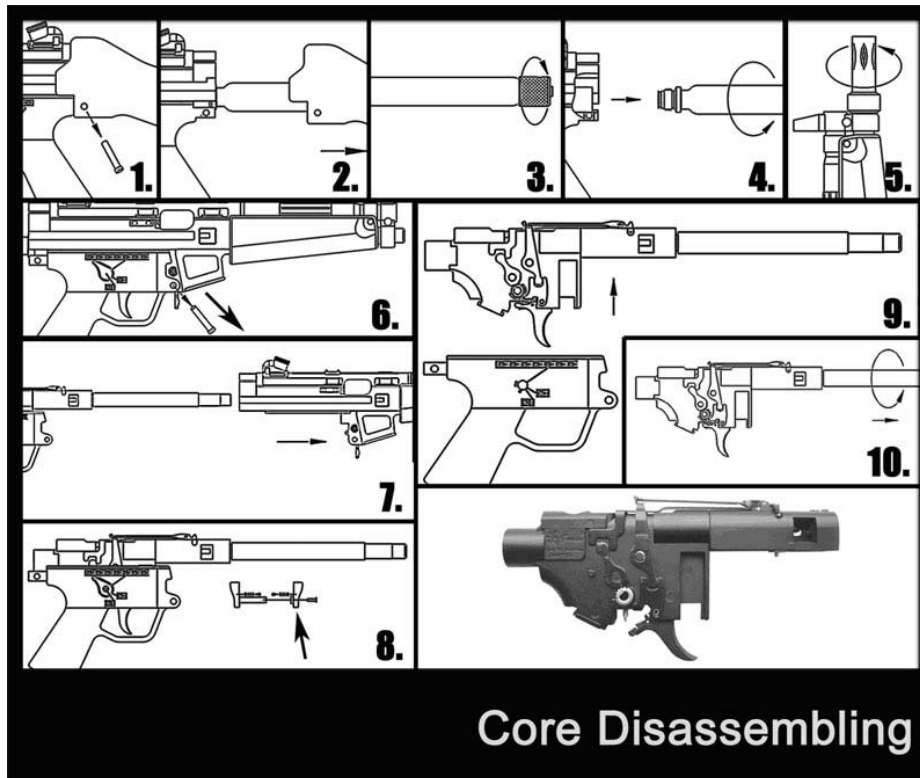

Core Disassembling

1. Remove the locking pin from the butt stock
2. Slide the butt stock out
3. Turn the CO2 Cylinder off and pull the trigger to release any reminding CO2 inside the marker. (Make sure point the marker to a safe direction)
4. Unscrew the CO2 Cylinder out
5. Take off the muzzle
6. Remove the locking pin from the marker body
7. Slide the upper body out
8. Unscrew the locking pin on the fire selector (see pic 8 for the location of "Locking Pin")
9. Separate the marker core and lower body
10. Unscrew the barrel



Warning

 Adult Only	<p>This paintball marker is not a toy nor is it intended for unsupervised use by any persons under the age of 18 years. Always keep in mind that the sport of Paintball will be viewed and judged upon your safe and sportsmanlike conduct.</p>
 Sport Only	<p>This paintball marker takes Co2 as energy source, takes paintball as projectile. This paintball marker must be used in the Real Action Exercise or Paintball Sport.</p>
 Mask On	<p>Do always wear eye protection in the form of approved goggles or full face mask and never shoot at a person who is not similarly protected.</p>
 Read	<p>Read the warning notice and user manual before you operate this paintball marker to prevent any unnecessary property damage or personal injury.</p>

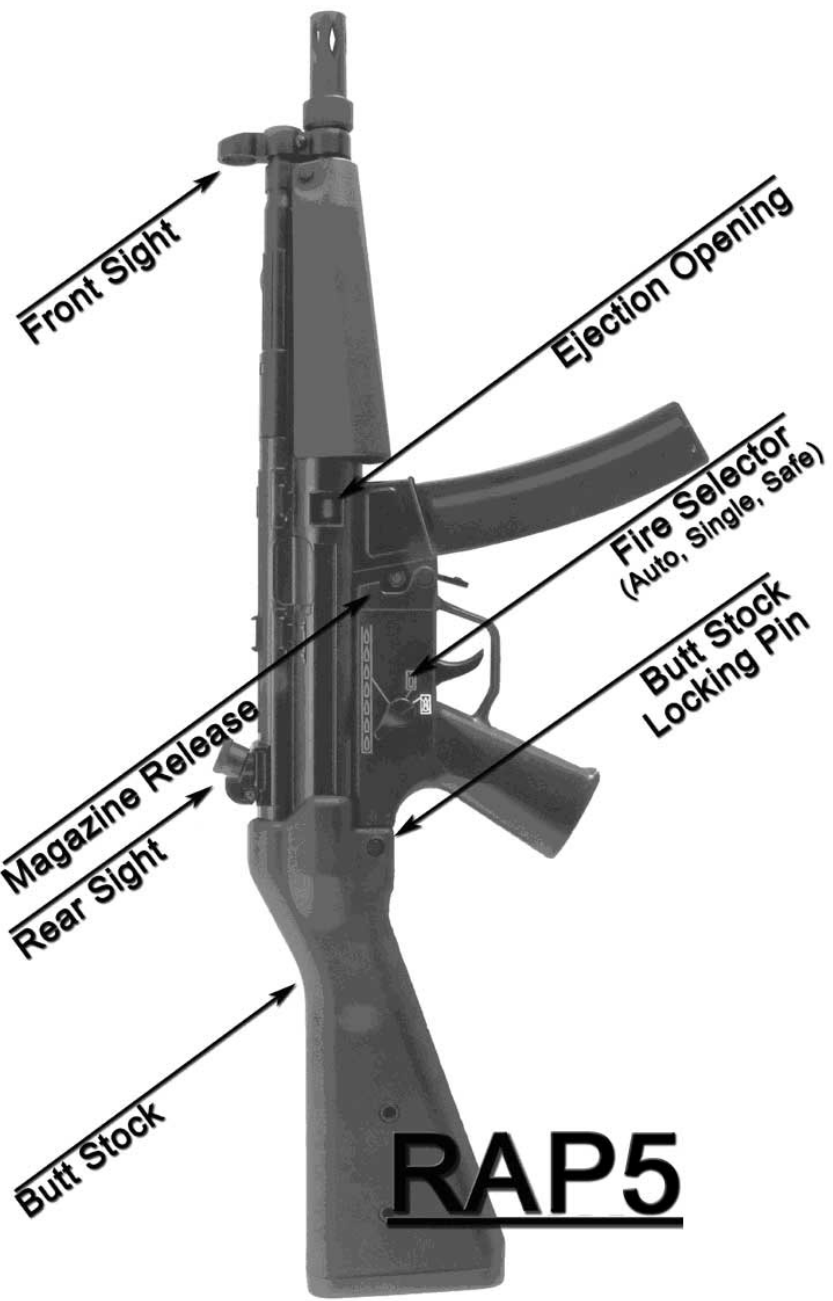

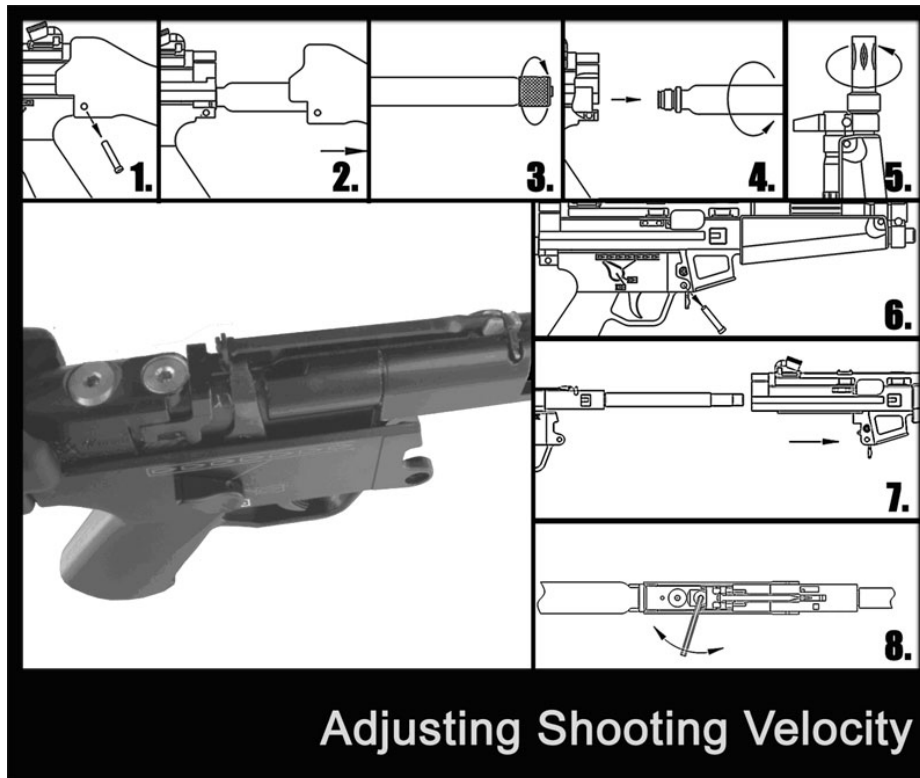

Adjusting Shooting Velocity

1. Remove the locking pin from the butt stock
2. Slide the butt stock out
3. Turn the CO2 Cylinder off and pull the trigger to release any reminding CO2 inside the marker. (Make sure point the marker to a safe direction)
4. Unscrew the CO2 Cylinder out
5. Take off the muzzle
6. Remove the locking pin from the marker body
7. Slide the upper body out
8. Use the provided tool to adjust the shooting velocity (must re-install the cylinder for adjust the Rate of Shooting)

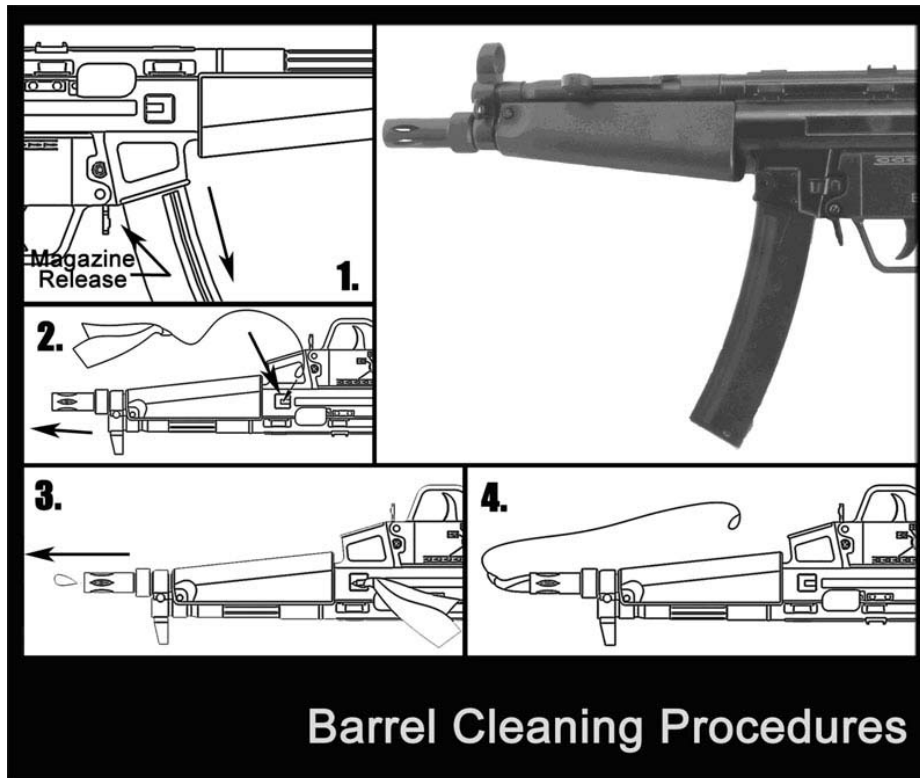

1. Unload the magazine by pressing the magazine release and pull the magazine out, make sure there is no paintball inside the “Ejection Opening”.
2. Pass one end of the “Cleaning Wire” through the “Ejection Opening” to the “Muzzle” and attach the “Cleaning Cloth” at the other end of the “Cleaning Wire”
3. Pull the “Cleaning Wire” from the “Muzzle” Slowly
4. Repeat this procedure with a cleaned “Cleaning Cloth” if necessary

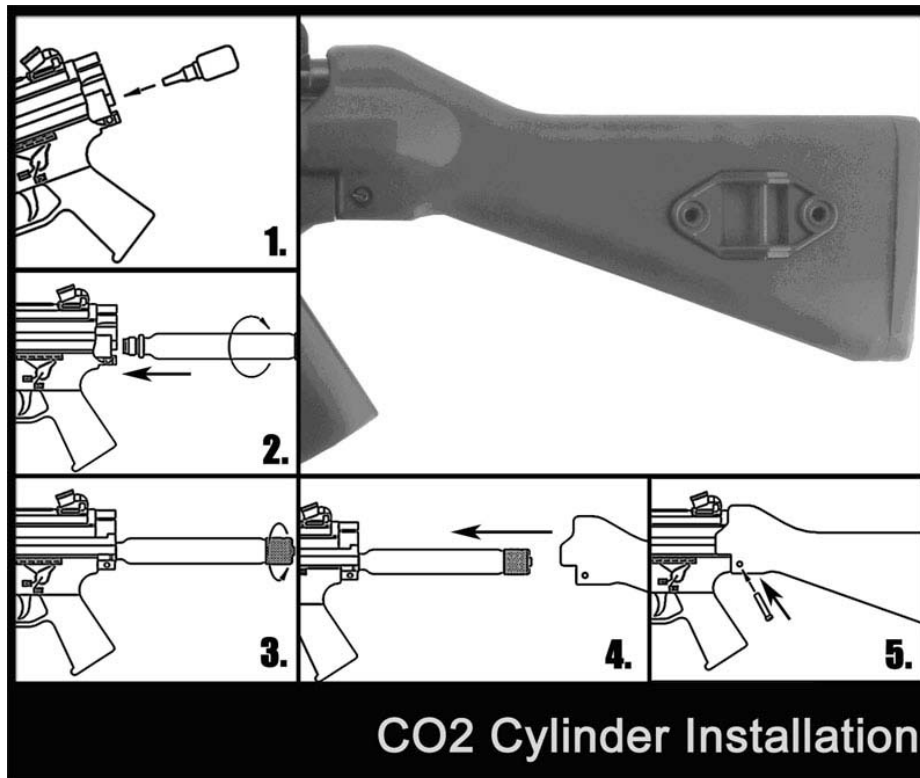

1. Apply 5-7 drops of lubricate oil into the end of the marker body
2. Install the CO2 Cylinder into the end of the marker body
3. Turn the CO2 Cylinder on (Two to Three Turns)
4. Slide the Butt Stock onto the end of the marker body
5. Push the Locking Pin in and lock the Butt Stock

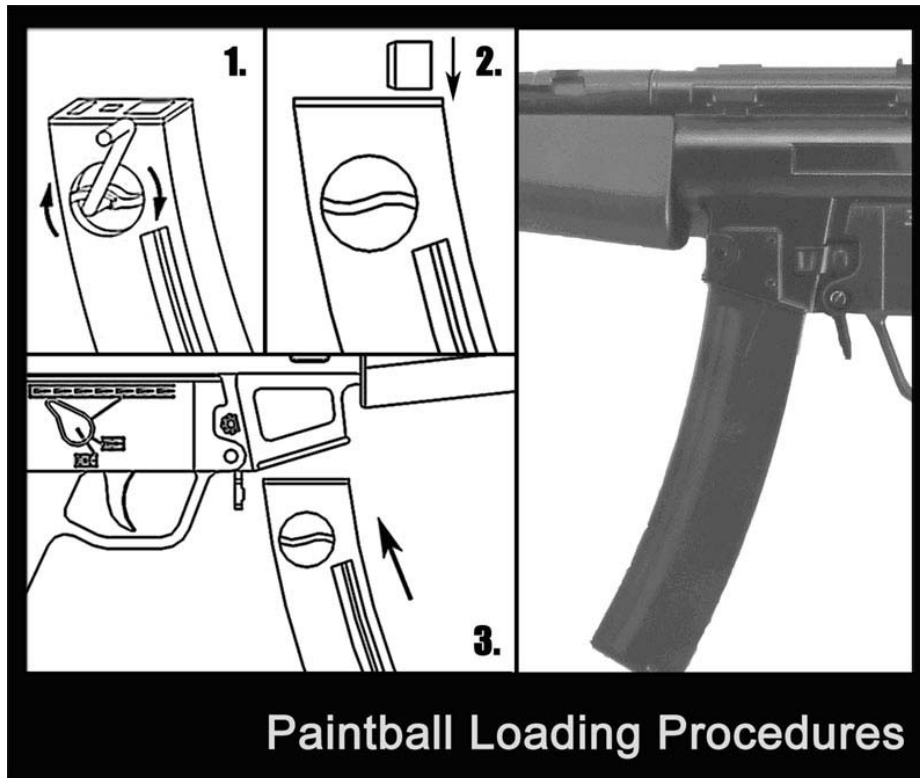

Paintball Loading Procedures

1. Twist the switch (clockwise) on the side of the RAP5 Magazine until it is tight.
2. Open the paintball package and flip up the lid inside of the package.
3. Load the paintball with cases in to the magazine with the opened side facing forward or follow the instructions on the lid of the paintball package.
4. Load magazine into the RAP5 with the up right direction.

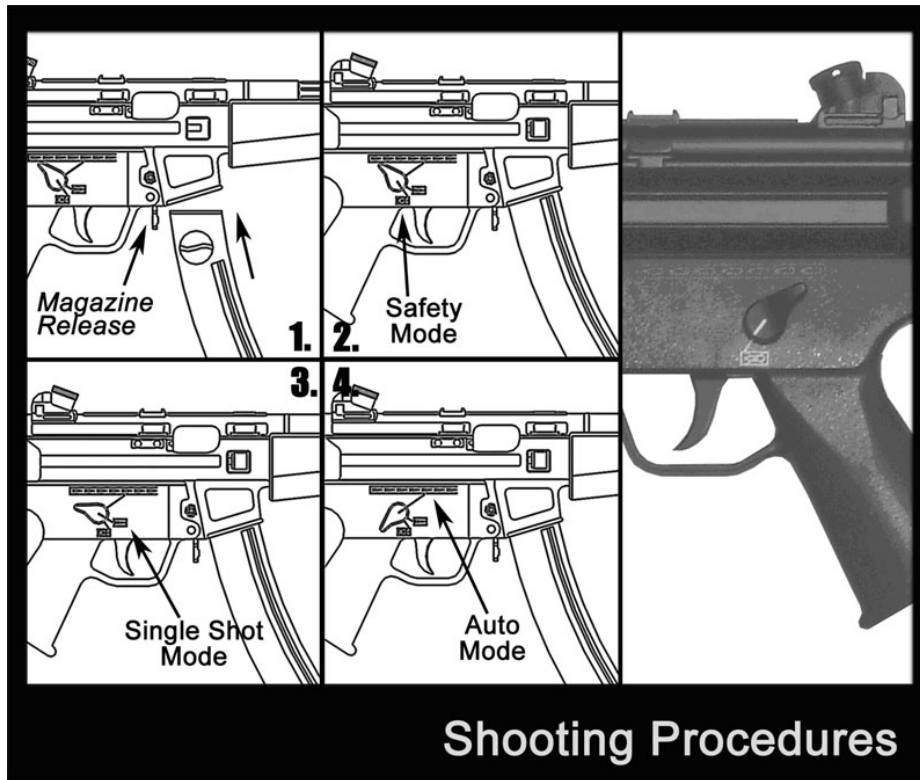

1. Load the Magazine from the bottom of the marker
2. Select the shooting mode by switching the fire selector
3. Aim and pull trigger to shoot

Important Notices

- a. Read the User Manual carefully before using the Marker to avoid any unnecessary accidents or injuries.
 - b. Only 18 years old or above to use the Marker.
 - c. Failure to follow the instructions may result in serious injury such as blindness and damage to the property.
 - d. Wear a protective mask or goggle at all time while using this marker to avoid paints and/or cartridge cases injury to the eyes.
 - e. DO NOT point or shoot with the Marker to any persons and yourself, it may cause blindness or other serious injury.
 - f. Keep the Gas Cylinder and the Marker away from fire or high temperature area (in excess of 113F or 45°C).
 - g. Only use Co2 to fill in the Gas Cylinder to operate the Marker.
 - h. DO NOT attempt to strip the Marker and gas cylinder when the gas cylinder is attached.
 - i. DO NOT load any pellets other than paintballs in the Marker.
 - j. Only suggested paintballs are used for the Marker.
 - k. DO NOT carry the Marker without case in the public area.
 - l. DO NOT ship the Marker or accessories except in the original package case.
 - m. DO NOT attempt to rebuild or modify the structure of the Marker. It may result in serious injury and damage to the Marker during use.
 - n. Remove the Gas Cylinder form the Marker after use, keep the Marker and the Gas Cylinder out of reach of the children at all time.
 - o. Ensure the adjustment of the muzzle energy (joule) of the Marker is within the limit of local laws.
 - p. Any injury during usage the Marker or any accessories should go to see Doctor immediately.
 - q. DO NOT ATTEMPT to repair the Marker or any accessories of this Marker by yourself, should refer to nearest Authorized Service Center.
- **DO NOT ATTEMPT to strip and assemble the Gas Cylinder or the main core.**
 - **Ensure the Safety Catch is always at SAFE before or after use**
 - **DO WEAR appropriate protective dress and mask when using the Marker**